

STARCH – TECHNICAL RIDER 2009

INPUT LIST

CH	INSTRUMENT	MIKE	BRAND	48V	FOH INSERT	STAND	BAND
1	BD	SM-91	SHURE	X	COMP	-	
2	SD 1	SM-57	SHURE		COMP	SSB	
3	SD 2	SM-57	SHURE		COMP	SSB	
4	HH	KM-185	NEUMANN	X		SSB	
5	RT 1	SM-98	SHURE	X	GATE	-	
6	RT 2	SM-98	SHURE	X	GATE	-	
7	FT	SM-98	SHURE	X	GATE	-	
8	OH LEFT	KM-185	NEUMANN	X		LSB	
9	OH RIGHT	KM-185	NEUMANN	X		LSB	
10	BASS	D.I.		X	COMP	-	
11	GUITAR	SM-57	SHURE		COMP	SSB	
12	KEYS LEFT	D.I.		X		-	
13	KEYS RIGHT	D.I.		X		-	
14	MOOG SYNTH	D.I.		X		-	
15	KORG SYNTH	D.I.		X		-	
16	SAX	SM-57	SHURE			LSB	
17	TRB	SM-57	SHURE			LSB	
18	TRP	SM-57	SHURE			LSB	
19	SOUSAPHON	C-519	AKG			-	X
20	HORN SOLO	SM-57	SHURE			LSB	
21	VOC LEAD	TGX930	BEYERDY.	X		LSB	X
22	VOC SAX	SM-58	SHURE			LSB	X
23	VOC GUEST	SM-58	SHURE			LSB	

SEND 1	LARGE HALL						
SEND 2	MEDIUM HALL						
SEND 3	TAP DELAY						

				CLUB	FESTVAL		
MON	KEYS	WEDGE		LINE 1	LINE 1		
MON	LEAD	WEDGE	+ IN EAR	FRONTMIX	LINE 2		X
MON	GUITAR	WEDGE		LINE 2	LINE 3		
MON	DRUMS	WEDGE		LINE 3	LINE 4		
MON	TRP	WEDGE		LINE 4	LINE 5		
MON	TRB	WEDGE		LINE 4	LINE 5		
MON	SAX	WEDGE		LINE 4	LINE 5		

SSB (SMALL STAND WITH BOOM) LSB (LARGE STAND WITH BOOM)

BAND: X = we bring our own equipment

STAGE PLOT

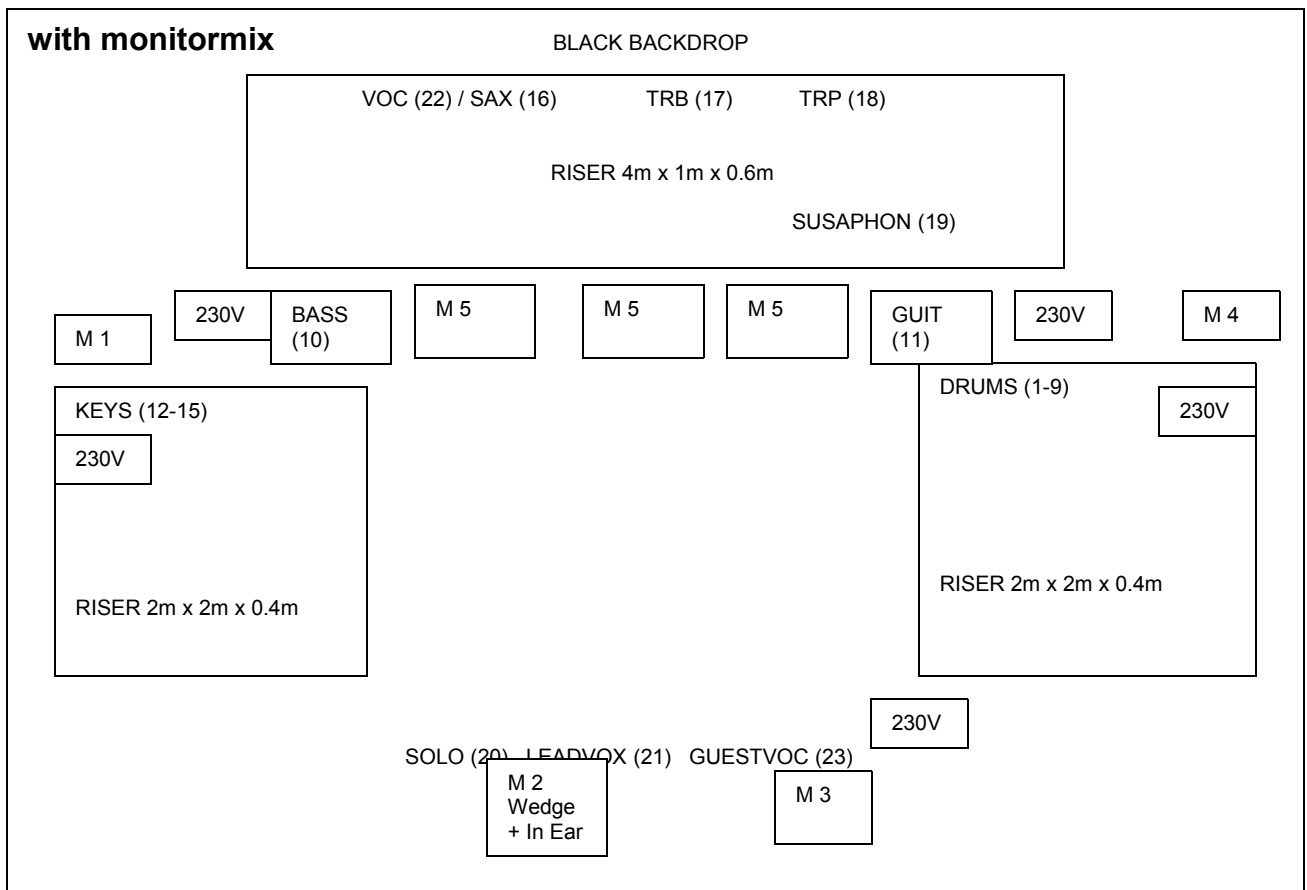
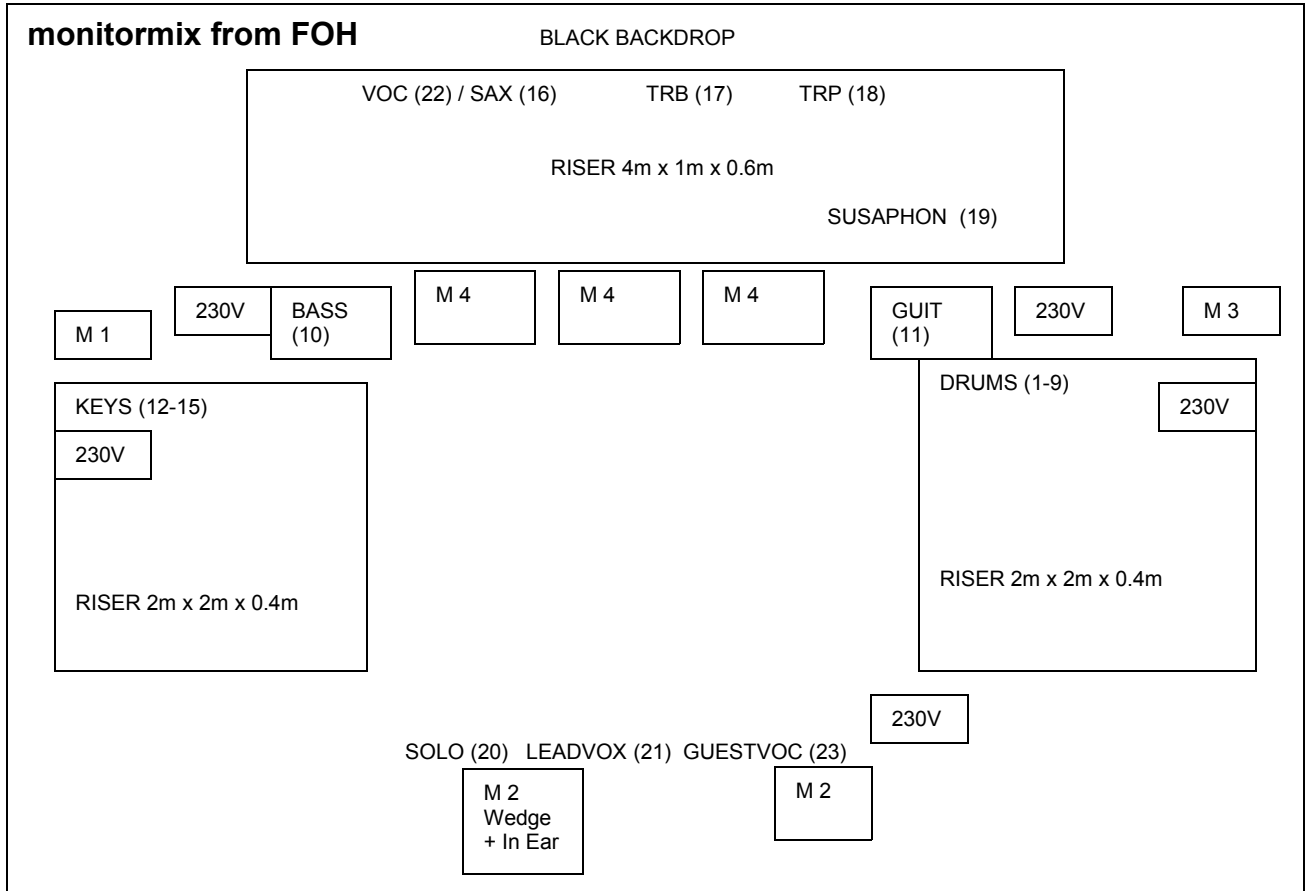

RISER:

Risers as on stage plot

LIGHTS:

Please aks for separate light rider

FOH:

Mixing Desk: M7CL / PM5D / DM2000 / XL4

Effects: 2 Reverbs, 1 Tap Delay

Dynamics: Gates + Compressors as on channel list

Driver: 2 x 31 Band EQ for L&R (plus 4 x 31Band EQ if monitor from FOH)

MON:

7 Wedges (same type)

we bring our own IN-EAR-system (LEAD VOC)

STAGE:

1 black backdrop

Stage Power (230V) as on stage plot

Mikes, D.I.s, Stands and Cables as on input list

Technical Contact:

Sonal Schönfeld (FOH) / +41 79 703 22 26 / sonal@earthbeatrecords.ch